



MEYLE[®]
Products



**The next
generation!**

**MEYLE water pumps –
pioneering advancements instead
of technological dead end!**

WHY choose CARBON WHEN you could have DIAMOND?

The majority of MEYLE water pumps are now fitted with a premium-grade mechanical seal engineered by a leading German sealing specialist. Designed to surpass conventional quality standards.

The distinguishing feature of this high-performance seal is the SiC/SiC (silicon carbide) pairing. Compared to conventional carbon- or hard carbon-based seals, silicon carbide provides almost the same hardness as a diamond.

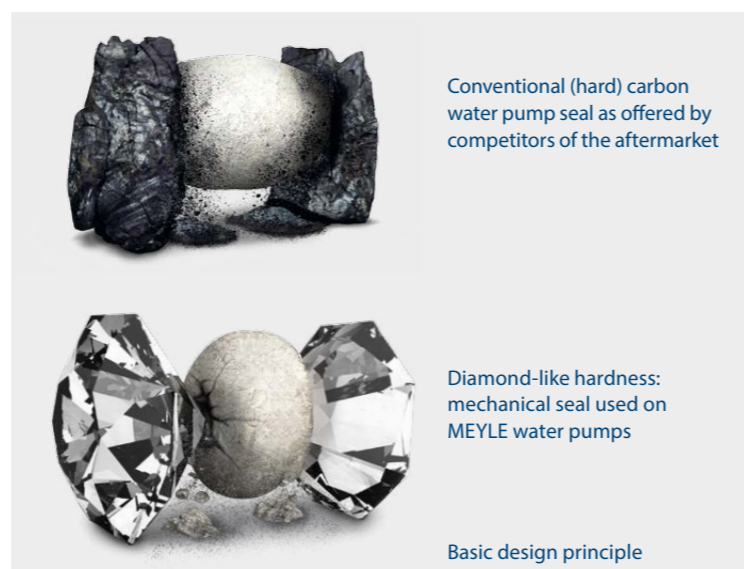

The new mechanical seals offer a huge spectrum of CONVINCING BENEFITS:

- > Two silicon carbide slide rings rotating relative to each other (SiC/SiC tribo pairs) ensure effective sealing. Unlike the materials typically used by aftermarket applications, SiC is a high-performance low-friction compound unequalled in resistance and service life.
- > The seal offers improved resistance to contaminated coolant. Its exceptionally narrow sealing gap (approx. 1µm) effectively reduces the number of critical particles penetrating the sealing gap. Tiny contaminants potentially trapped between the sealing faces are effectively ground down to minute particles, eliminating any risk of early part failure. This is the key to long service life.
- > The seal offers improved resistance to coolant additives.

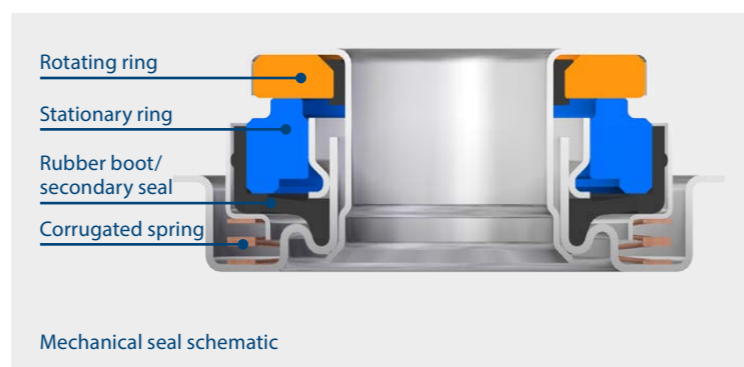

- > The secondary seals (rubber boot) are made of a high-performance elastomer HNBR material which offers superb temperature and weather resistance.

MEYLE is the only brand to supply the independent aftermarket with water pumps fitted with this type of high-durability mechanical seal.

PUT an END to LEAKS: MEYLE-HD water pumps

The MEYLE range now also features six new water pumps in HD quality to fit a wide variety of VW models. By combining uniquely tough components, MEYLE-HD water pumps offer quality standards far higher than what can normally be found on the free market for components:

- > Made in Germany.
- > Extremely hard-wearing mechanical seal in OE quality with SiC/SiC seal faces (silicon carbide) and high resistance to abrasive materials
- > Housing seal resistant to high temperatures
- > Water pump bearings in OE-equivalent quality with four-point contact ball/roller bearings, depending on the operating conditions – improved distribution of excessive radial forces, optimised axial support. Angular contact ball bearing – supports axial and moderately high radial forces, optimised axial support minimises axial play.
- > High-performance grease ensures a long pump life.
- > **Four-year warranty on all MEYLE-HD parts.**

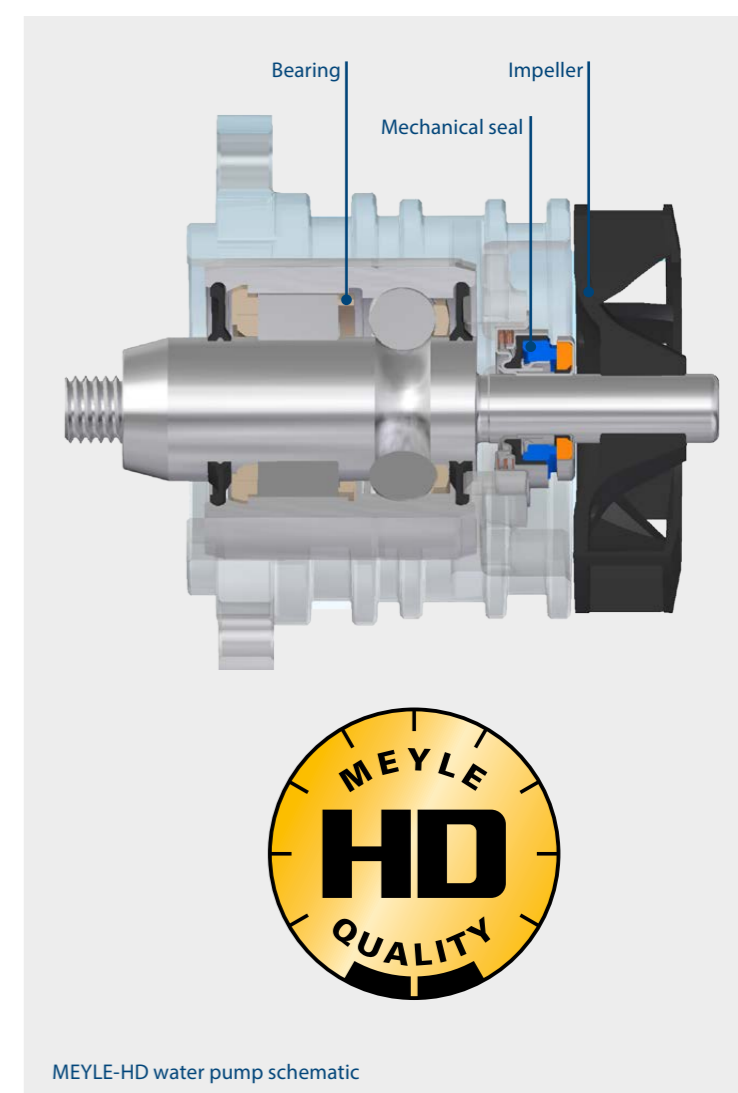

The new MEYLE-HD water pumps are available for the following vehicle applications in the Volkswagen range:

MEYLE no. 113 220 0018/HD	Suitable for VW diesel engines 1.9–2.0 TDI
MEYLE no. 113 012 0042/HD	Suitable for VW diesel engines 2.5 TDI
MEYLE no. 113 220 0005/HD	Suitable for VW diesel engines 2.5 TDI

MEYLE no. 113 012 0033/HD	Suitable for VW petrol engines 1.6i 1.8i 2.0i
MEYLE no. 113 220 0023/HD	Suitable for VW petrol engines 1.8 TSI 2.0 TSI
MEYLE no. 113 220 0011/HD	Suitable for VW petrol engines 2.0 TFSI



Wulf Gaertner Autoparts AG

Merkurring 111 • 22143 Hamburg • Germany

contact@meyle.com • www.meyle.com

Our brands:



Your source for MEYLE parts:

777 200 0498

